

Digital Attenuator, 15 dB, 4-Bit DC - 2 GHz

AT-210

V 2.00

Features

- Attenuation 1-dB Steps to 15 dB
- High Accuracy +/-3%
- Temperature Stability +/-0.15 dB from -40°C to +85°C
- Low Intermodulation Product: +50 dBm IP₃
- Low DC Power Consumption: 50 μW
- Low Cost SOIC16 Plastic Package
- Tape and Reel Packaging Available¹

Description

M/A-COM's AT-210 is a 4-bit, 1-dB step GaAs MMIC digital attenuator in a low cost SOIC 16-lead surface mount plastic package. The AT-210 is ideally suited for use where high accuracy, fast switching, very low power consumption and low intermodulation products are required. Typical applications include radio, cellular, and wireless LANs, GPS equipment and other Gain/Level Control circuits.

The AT-210 is fabricated with a monolithic GaAs MMIC using a mature 1-micron process. The process features full chip passivation for increased performance and reliability.

SO-16

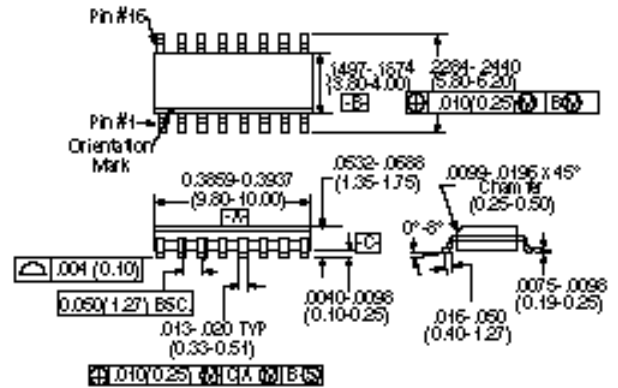

16-Lead SOP outline dimensions
Narrow body .150
(All dimensions per JEDEC No. MS-012-AC, Issue C)
Dimensions in () are in mm.
Unless Otherwise Noted: .xxx = ±0.10 (.xxx = ±0.25)
.xx = ±0.02 (.x = ±0.5)

Ordering Information

Part Number	Package
AT-210 PIN	SOIC 16-Lead Plastic Package
AT-210TR	Forward Tape & Reel
AT-210RTR	Reverse Tape & Reel

Electrical Specifications, T_A = +25°C

Parameter	Test Conditions ²	Unit	Min.	Typ.	Max
Reference Insertion Loss	DC - 0.1 GHz	dB		0.9	1.2
	DC - 0.5 GHz	dB		1.3	1.5
	DC - 1.0 GHz	dB		1.5	1.8
	DC - 2.0 GHz	dB		1.8	2.0
Attenuation Accuracy ³	DC - 1.0 GHz DC - 2.0 GHz	dB	±(0.15 dB + 3% of Attenuation Setting in dB) ±(0.30 dB + 3% of Attenuation Setting in dB)		
VSWR				1.8:1	
Trise, Tfall Ton, Toff Transients	10% to 90% RF, 90% to 10% RF	nS		10	
	50% Control to 90% RF, 50% Control to 10% RF	nS		15	
	In Band	mV		18	
1 dB Compression	Input Power 0.05 GHz	dBm		22	
	Input Power 0.5 - 2.0 GHz	dBm		28	
IP ₂	Measured Relative to Input Power 0.05 GHz	dBm		49	
	(For two-tone Input Power Up to +5 dBm) 0.5 - 2.0 GHz	dBm		72	
IP ₃	Measured Relative to Input Power 0.05 GHz	dBm		45	
	(For two-tone Input Power Up to +5 dBm) 0.5 - 2.0 GHz	dBm		50	

1. Refer to "Tape and Reel Packaging"Section, or contact factory.

2. All measurements at 1 GHz in a 50 Ω system, unless otherwise specified.

3. Attenuation accuracy specifications apply with negative bias control and low inductance grounding.

Absolute Maximum Ratings

Parameter	Absolute Maximum ¹
Max. Input Power 50 MHz	+27 dBm
500-2000 MHz	+34 dBm
Control Voltage	+5 V, -8.5 V
Operating Temperature	-40°C to +85°C
Storage Temperature	-65°C to +150°C

1.Operation of this device above any one of these parameters may cause permanent damage.

Functional Schematic

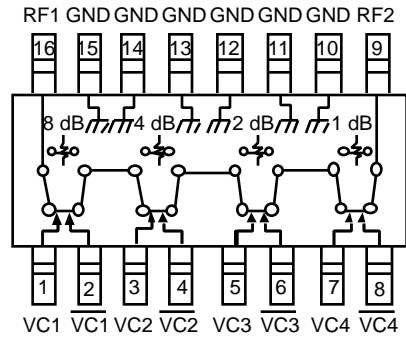

Pin Configuration

Pin	Description	Pin No.	Description
1	VC1	9	RF2
2	$\overline{VC1}$	10	GND
3	VC2	11	GND
4	$\overline{VC2}$	12	GND
5	VC3	13	GND
6	$\overline{VC3}$	14	GND
7	VC4	15	GND
8	$\overline{VC4}$	16	RF1

Truth Table

Control Inputs								Attenuation (dB)
$\overline{VC4}$	VC4	$\overline{VC3}$	VC3	$\overline{VC2}$	VC2	$\overline{VC1}$	VC1	
1	0	1	0	1	0	1	0	Reference
0	1	1	0	1	0	1	0	1 dB
1	0	0	1	1	0	1	0	2 dB
1	0	1	0	0	1	1	0	4 dB
1	0	1	0	1	0	0	1	8 dB
0	1	0	1	0	1	0	1	15 dB

"0" = Vin Low, Vin Low = 0V, "1" = Vin High, Vin High = -5V
 "0" = 0 to -0.2V @ 20µA Max
 "1" = -5V @ 10 µA typ to -8V @ 200 µA Max

Typical Performance

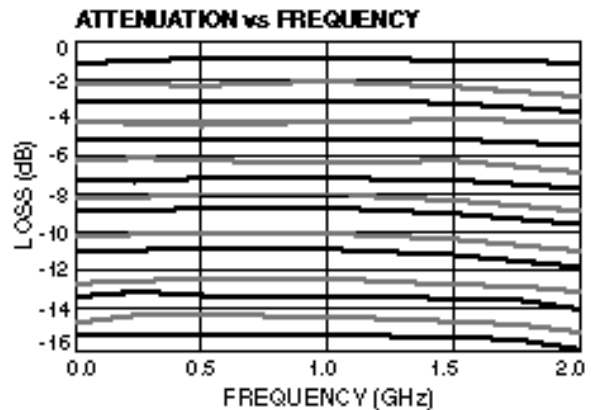
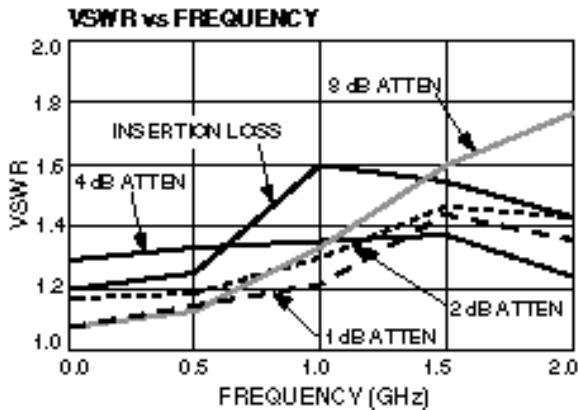
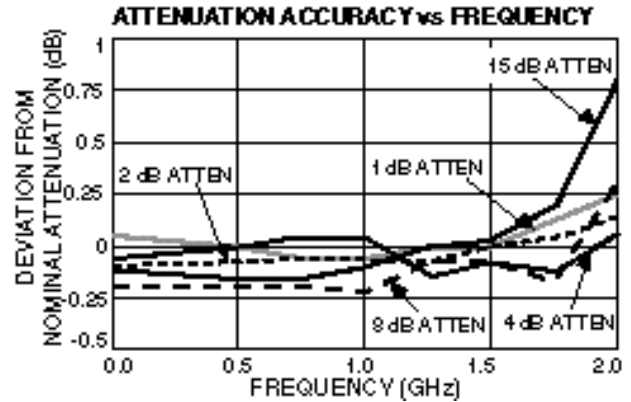
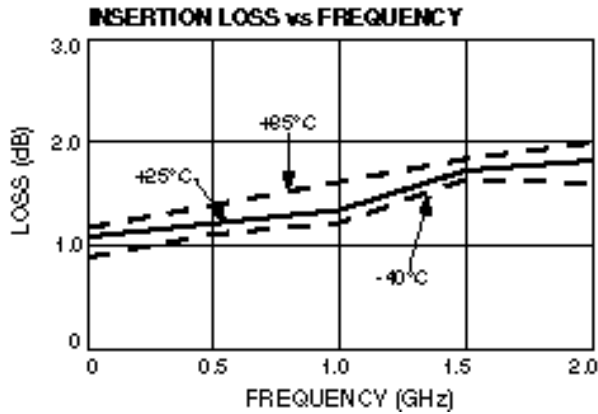

This datasheet has been download from:

www.datasheetcatalog.com

Datasheets for electronics components.